



*Designed
with great
visibility, easier
maintenance,
and superior
durability.*

Move more loads faster, minimize damage and stay competitive.

APPLICATIONS

Designed for any application using pallets or containers to load trucks, Cascade's Single-Double Pallet Handler allows single pallet handling without protrusion outside the truck profile. Spreading the forks hydraulically allows handling of two pallets side by side. Sideshifting provides added flexibility for aligning forks or pallets in tight areas.

FEATURES

- Superior visibility through and over the frame for damage free handling at all stacking heights
- All steel frame for increased overall durability, eliminating flexing
- Easy access cylinders can be resealed without removing for quick servicing
- Bolt-on Interchangeable forks for low service cost
- Full-length, fully enclosed wrap around UHMW plastic bearings provide maximum strength and full bearing support, greatly reducing wear on bearing surface
- Parabolic fork heel increases longevity in this normally high-wear area
- Dual class 2 and 3 mountings, easily field converted
- Inner forks mounted on a chrome pin for greater inner fork stability
- Adjustable fork set spread for ability to handle Euro or international pallets (560 to 640)

OPTIONS

- Various load backrest configuration heights, fork lengths and sections
- Various fork set spreads and opening ranges
- Quick-disconnect lower hooks
- Drop shank forks—forks are lowered relative to the attachment frame
- Independent fork set control—allows moving left or right fork set independent of the opposite fork set
- Non-Sideshifting models available



SINGLE-DOUBLE PALLET HANDLER

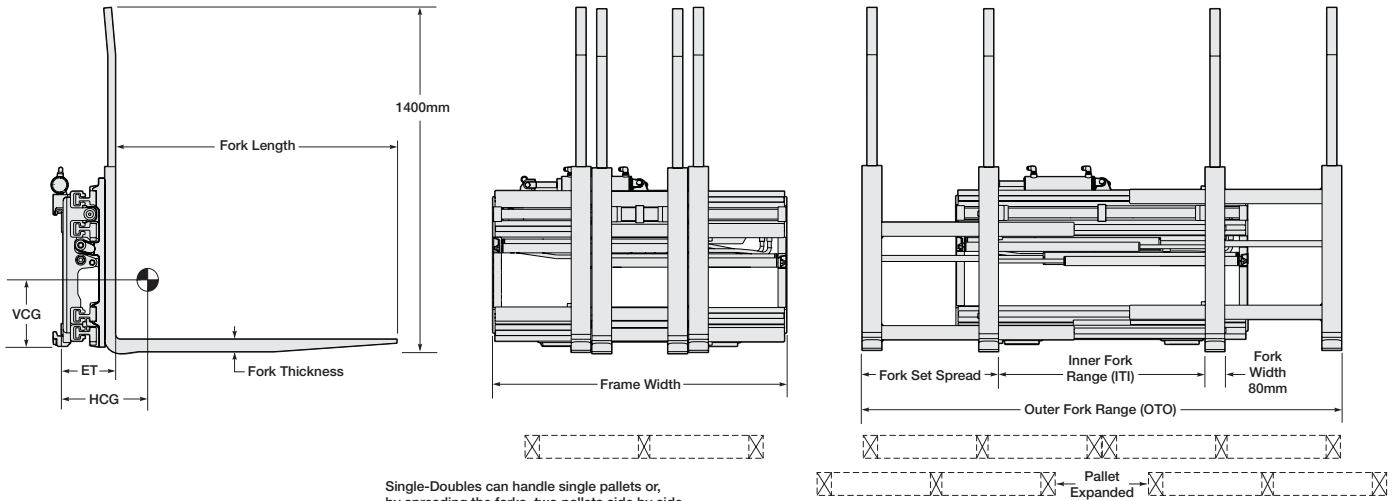

Sideshifting

Model Number	Capacity KG	Pallet Type	Opening Range OTO MM	Opening Range ITI MM	Fork Set Spread MM	Frame Width MM	Fork Length X Section MM	Weight KG	Effective Thickness ET MM	Horizontal Ctr. of Gravity MM	Vertical Ctr. of Gravity MM	Mounting Class	Sideshift Stroke MM	Backrest Height MM
20G-FDS-A400 ②	2000	1200 x 800 EURO.-PALLET	520-1650	230	520	970	1150x80x40	460	217	244	269	2	200	1400
20G-FDS-A401 ③	2000	1200 x 800 EURO.-PALLET	560-1700	230	560	930	1150x80x40	457	217	245	269	2	200	1400
22G-FDS-A501 ①	2200	1200 x 800 EURO.-PALLET	560-1970	230	560	1200	1150x80x40	508	221	228	283	2	200	1400
25G-FDS-A501 ①	2500	1200 x 800 EURO.-PALLET	560-1970	230	560	1200	1150x80x45	516	226	234	272	2	200	1400
25G-FDS-B501 ①	2500	1200 x 800 EURO.-PALLET	560-1970	230	560	1200	1150x80x45	516	221	236	278	3	200	1400
28G-FDS-B511 ①	2800	1200 x 800 EURO.-PALLET	560-1970	230	560	1200	1150x80x50	536	226	247	273	3	200	1400
32G-FDS-B501 ①	3200	1200 x 800 EURO.-PALLET	560-1970	230	560	1200	1150x80x60	558	236	267	248	3	200	1400
22G-FDS-A500	2200	1200 x 1000 INT.-PALLET	660-2040	330	640	1200	1150x80x40	512	221	227	283	2	200	1400
25G-FDS-A500	2500	1200 x 1000 INT.-PALLET	660-2040	330	640	1200	1150x80x45	517	226	234	274	2	200	1400
25G-FDS-B500	2500	1200 x 1000 INT.-PALLET	660-2040	330	640	1200	1150x80x45	517	221	238	278	3	200	1400
28G-FDS-B510	2800	1200 x 1000 INT.-PALLET	660-2040	330	640	1200	1150x80x50	536	226	249	273	3	200	1400
32G-FDS-B500	3200	1200 x 1000 INT.-PALLET	660-2040	330	640	1200	1150x80x60	557	236	267	250	3	200	1400
25G-FDS-A520	2500	1200 x 1000 AUCTION-PALLET	815-2210	485	710	1150	1000x80x45	505	226	206	279	2	200	1400
25G-FDS-B520	2500	1200 x 1000 AUCTION-PALLET	815-2210	485	710	1150	1000x80x45	505	221	210	283	3	200	1400
25G-FDS-A521	2500	1200 x 1000 AUCTION-PALLET	700-2100	370	685	1150	1000x80x45	500	226	209	280	2	200	1400
25G-FDS-B521	2500	1200 x 1000 AUCTION-PALLET	700-2100	370	685	1150	1000x80x45	500	221	213	284	3	200	1400

- ▶ The outer fork tines are higher than the inner fork tines
- ▶ 200mm total sideshift
- ▶ Plastic pallets may require modified fork dimensions
- ▶ 980mm minimum required truck carriage width.

- ① Can also handle 1200 x 1000 pallet on the 1000 side.
- ② Suitable for Dusseldorfer pallets 800 x 600.
- ③ Suitable for display pallets 800 x 600.

HYDRAULIC FLOW AND PRESSURE

Minimum	Recommended	Maximum	Operating Pressure
15 l/min	27 l/min	27 l/min	200 BAR

HYDRAULIC FUNCTIONS

Hydraulic Functions	Truck Auxiliary Valves Required
2	2

INSTALLATION KITS

Model	Catalog Order No.
Class 2	6072233
Class 3	6072234

CONVERSION KIT

Models	Conversion	Catalog Order No.
25G / 28G	Class 2 to 3	6072573
25G / 28G	Class 3 to 2	6072574

Cascade Europe • Damsluisweg 56 • PO Box 3009 • 1300 EL, Almere, Netherlands • Tel +31 (0)36 54 92 911 • Fax +31 (0)36 54 92 964
 Cascade (UK) Ltd. • Unit 4, 12 O'Clock Court • 21 Attercliffe Road • Sheffield S4 7WW, England • Tel +44 (0) 870 850 8756 • Fax +44 (0) 870 850 8757