



Allows the handling of up to four pallets at a time.

Move one to four pallets with one versatile solution.

APPLICATIONS

The Single-Double-Four Pallet Handler equipped with long forks allows you to move up to two pallets wide and two deep for a total of up to four pallets in one load. Move loads faster, minimize damage and stay competitive while helping your organization stay green by the realized energy savings. Designed for any application using pallets or containers to load trucks. Spreading the forks hydraulically allows handling of up to four pallets. Sideshifting provides added flexibility for aligning forks or pallets in tight areas.

FEATURES

- Superior visibility through and over the frame for damage free handling at all stacking heights
- All steel frame for increased overall durability, eliminating flexing
- Easy access cylinders can be resealed without removing for quick servicing
- Bolt-on Interchangeable forks for low service cost
- Full-length, fully enclosed wrap around UHMW plastic bearings provide maximum strength and full bearing support, greatly reducing wear on bearing surface
- Parabolic fork heel increases longevity in this normally high-wear area
- Inner forks mounted on a chrome pin for greater inner fork stability
- Adjustable fork set spread for ability to handle Euro or International pallets (560 to 710mm wide).

OPTIONS

- Various load backrest configuration heights, fork lengths and sections
- Various fork set spreads and opening ranges
- Quick-disconnect lower hooks
- Drop shank forks—forks are lowered relative to the attachment frame
- Independent fork set control—allows moving left or right fork set independent of the opposite fork set
- Non-Sideshifting models available



MULTIPLE PALLET HANDLER LONG FORKS

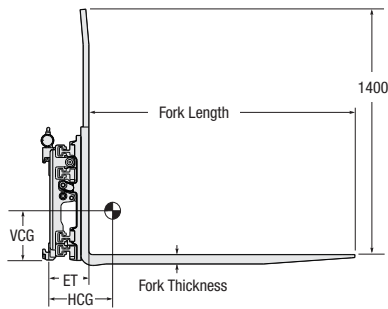

Long Fork Single-Double Pallet Handlers can handle one to two pallets or, by spreading the forks, four pallets.

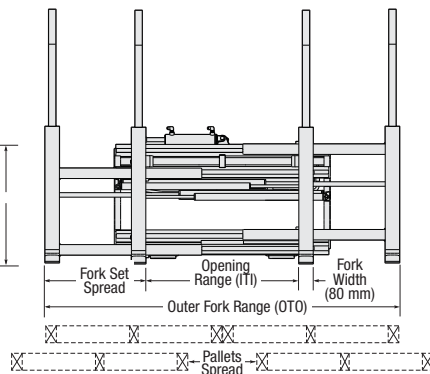
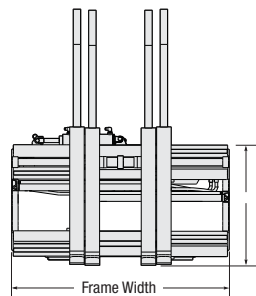

Model Number	Capacity @ 1200mm Load Centre KG	Pallet Type	Opening Range OTO MM	Opening Range ITI MM	Fork Set Spread MM	Frame Width MM	Fork Length X Section MM	Weight KG	Effective Thickness ET MM	Horizontal Ctr. of Gravity MM	Vertical Ctr. of Gravity MM	Mounting Class	Sideshift Stroke MM	Backrest Height MM
1-2-4 Pallets														
12G-FQS-A501	1250	1200 X 800 EURO.-PALLET	560-1970	455	560	1200	2400X80X50	697	231	596	202	2	200	1400
12G-FQS-B501	1250	1200 X 800 EURO.-PALLET	560-1970	375	560	1200	2400X80X50	697	226	594	202	3	200	1400
12G-FQS-A520	1250	1200 X 1000 AUCTION-PALLET	815-2095	340	710	1150	1980X80X50	678	231	449	250	2	200	1400
12G-FQS-B520	1250	1200 X 1000 AUCTION-PALLET	815-2095	415	710	1150	1980X80X50	678	226	444	250	3	200	1400
25G-FQS-B505	2500	1200 X 1000 INTL.-PALLET	660-2070	330	640	1250	2400X80X65	937	259	564	239	3	200	1400
25G-FQS-B506	2500	1200 X 800 EURO.-PALLET	560-1970	230	560	1250	2400X80X65	930	259	567	238	3	200	1400
36G-FQS-C506	3600	1200 X 800 EURO.-PALLET	560-1970	230	560	1350	2400X80X65	979	264	581	189	4	200	1400
46G-FQS-C506	4600	1200 X 800 EURO.-PALLET	560-1970	230	560	1450	2400X80X70	1050	270	584	186	4	200	1400

- ▶ The outer fork tines are higher than the inner fork tines
- ▶ 200mm total sideshift

- ▶ 980mm minimum required truck carriage width
- ▶ For forks shorter than 5150mm in length see standard Single-Double models.

HYDRAULIC FLOW AND PRESSURE

Minimum	Recommended	Maximum	Operating Pressure
15 l/min	27 l/min	27 l/min	200 BAR

HYDRAULIC FUNCTIONS

Hydraulic Functions	Truck Auxiliary Valves Required
2	2

INSTALLATION KITS

Model	Catalog Order No.
Class 3	6072234
Class 4	6090620

Cascade Europe • Damsluisweg 56 • PO Box 3009 • 1300 EL, Almere, Netherlands • Tel +31 (0)36 54 92 911 • Fax +31 (0)36 54 92 964
 Cascade (UK) Ltd. • 3 Kellbrook Road • Parkhouse Industrial Estate • Openshaw, Manchester M11 2DD, England • Tel 0044 (0) 800 243015 • Fax +0044 (0) 161 438 4055