



## HIGH PERFORMING, COMFORTABLE, SAFE ELECTRIC COUNTERBALANCED TRUCKS

### Productivity in safety

- The BLITZ 3R 48 Volt range is designed to guarantee unbeatable productivity with the highest degree of safety for both operator and load.
- BLITZ 3R lift trucks are equipped with two 6 kW drive motors and a 12 kW lift motor. All motors are AC type, controlled by a three-phase inverter with MOSFET electronics. This provides high drive speed, smooth and gradual acceleration, with no jerking or jolting starts, as well as excellent lifting performance, even for the most demanding applications.
- The two independent drive motors, together with the electronic differential, make the truck superbly agile even in the tightest spaces.
- Extremely stable thanks to the low centre of gravity and speed-reduction when cornering, calibrated in proportion to the steering angle.
- Active safety is a standard which CESAB guarantees. Its features are speed reduction when cornering, lock-out of fork lowering, integral in the Multifunction Armrest, and the automatically engaged parking brake.
- Mast movements can be controlled by means of **lever, Fingertips and Mini-Joystick controls, integrated in the Multifunction Armrest.**
- The mast structure and position of the specially designed lifting cylinders guarantee visibility combined with rigidity even at the greatest heights.



- The oil-immersed disc brakes provide smooth, gradual braking; what's more, this type of unit requires no maintenance and is ideal for applications with dust or damp, or in aggressive environment.

### Operator comfort, for a better job

- The ergonomic driving seat assures top comfort even for heavy duty applications.
- Seat designed by CESAB, with a special focus on driving posture and ease of working movements (upper body rotation, operation of controls, forearm rest).

- Control panel providing all controls, easily to hand, clearly visible, intuitive and user-friendly.
- Steering column angle adjustable for correct steering wheel positioning.



### Everything under control

- CESAB has made ease-of-use its top priority in the development of the **Operator Smart Control (OSC)**, featuring a new-generation display and keypad.
- Main data displayed include battery charge level, guided use programme, time, speed, hour-counter and rear wheel position.
- Display settings include a choice of 3 hour-counter modes for display: lifting, key hours and working hours.
- The display data only appear when they are needed, so the operator is not distracted from the job in hand.
- Rear wheel position is only displayed with the truck at a standstill, and the speed only with the truck in motion.



### Truck management: the on-board panel

- In the event that truck access control is required, the system is able to identify up to 40 different users, each with their own **Password.**
- Parameter **pre-setting** allows users to customise a number of functions, such as travel and lifting, and link them to a specific password and profile.

- Truck diagnostics are shown directly on the display, with easily interpreted ideograms: the operator can identify any malfunctions at a glance.



### Stopping when needed

- The technology which permits perfect control on slopes, impeccable emergency stopping, or automatic parking brake engagement is available on all Blitz 3R models.
- **Automatic Parking Brake (APB)**, with enabling switch, allowing easy truck stopping, on the level or on slopes.
- **Emergency button**, to stop the truck at once.

### Managing a fleet: CBM

With **CounterBalance Management (CBM)**, the customer is provided with various features for fleet management, which make this process more efficient and secure:

- Universal key
- 40 Programmable passwords
- 5 Profiles, with customised settings
- Scheduled servicing control
- Battery charge level control

### Options

- Multifunction Armrest with Fingertips or Mini-Joystick controls
- Three types of pedal drive controls available on any model
- Masts with lifting height up to 7 meters
- Fork carriage plate and integral side-shifter of different widths
- NFL & FFL, duplex and triplex versions available for all masts
- Standard and raised full cabs and Protection multiglass panels
- Fabric (Privilege) and heated (Elite) seat
- Various front and rear light layouts
- Cold-store version (-20°C)
- Tyres for all types of paving

Your Local Dealer

Cesab Carrelli Elevatori SpA  
Via Persicetana Vecchia, 10 - 40132 Bologna (Italy)  
Tel. +39 051 20.54.11 - Fax +39 051 72.80.07  
website: www.cesab-forklifts.com  
e-mail: cesab@cesab.it

Cesab Ltd:  
Unit 10, Regent Park, Booth Drive, Park Farm South  
Wellingborough, Northamptonshire, NN8 6R  
Tel. +44 (1) 933 670 460 - Fax +44 (1) 933 679 859  
e-mail: sales@cesab.net



# Blitz 3R

## THREE WHEELS ELECTRIC COUNTERBALANCED TRUCKS, FRONT WHEEL DRIVE

Designed for unbeatable agility, the new front wheel drive CESAB BLITZ 3R AC Technology is available with capacities from 1200 to 2000 Kg and lifting heights up to 7000 mm.

- **AC technology on drive and lifting**
- **Exceptionally rigid masts with outstanding visibility**
- **Comfortable, ergonomic driving seat**
- **Choice of parameter setups**
- **Automatically-engaged parking brake**
- **Wide range of options available**



0342070 - 04/07

gr\_a\_arch\_01/01

CESAB S.p.A. products, specifications and technical data are subject to change without notice.

# Blitz 3R

## VDI 2198

		CESAB	CESAB	CESAB	CESAB	CESAB	CESAB	CESAB		
Characteristics	1.1	Manufacturer	CESAB	CESAB	CESAB	CESAB	CESAB	CESAB		
	1.2	Model designation	BLITZ 312	BLITZ 315	BLITZ 316	BLITZ 318	BLITZ 316L	BLITZ 318L	BLITZ 320	
	1.3	Power unit: electric (battery), diesel, petrol, LPG	electric	electric	electric	electric	electric	electric	electric	
	1.4	Operation: manual, pedestrian, stand-on, driver seated	driver seated	driver seated	driver seated	driver seated	driver seated	driver seated	driver seated	
	1.5	Load capacity	Q (kg)	1200	1500	1600	1800	1600	1800	2000
	1.6	Load centre	c (mm)	500	500	500	500	500	500	500
	1.8	Axle centre to fork face	x (mm)	365.5 (b)	365.5 (b)	365.5 (b)	365.5 (b)	365.5 (b)	365.5 (b)	365.5 (b)
	1.9	Wheel-base	y (mm)	1300	1300	1410	1410	1542	1542	1542
	Weights	2.1	Weight	kg	2960 (a)	3190 (a)	3230 (a)	3375 (a)	3335 (a)	3440 (a)
2.2		Axle load with load, front/rear	kg	3685 / 475	4200 / 490	4370 / 460	4695 / 480	4355 / 580	4690 / 550	4985 / 580
2.3		Axle load without load, front/rear	kg	1675 / 1285	1680 / 1510	1740 / 1490	1770 / 1605	1845 / 1490	1860 / 1580	1850 / 1715
Wheels and chassis	3.1	Tyres: C=Cushion, SE=Superelastic, PN=Pneumatic, TW=Twin	C - SE - PN (c)	C - SE - PN (c)	C - SE - PN (c)	C - SE	C - SE - PN (c)	C - SE	C - SE	
	3.2	Tyre size, front	432x152 - 18x7.8 - 18x7.8	432x152 - 18x7.8 - 18x7.8	432x152 - 18x7.8 - 18x7.8	457x178 - 200/50-10	432x152 - 18x7.8 - 18x7.8	457x178 - 200/50-10	457x178 - 200/50-10	
	3.3	Tyre size, rear	381x127 - 16x6.8	381x127 - 16x6.8	381x127 - 16x6.8	381x127 - 16x6.8	381x127 - 16x6.8	381x127 - 16x6.8	381x127 - 16x6.8	
	3.5	Wheels, number front/rear (x = driven)	2x / 2	2x / 2	2x / 2	2x / 2	2x / 2	2x / 2	2x / 2	
	3.6	Track width, front	b10 (mm)	839 - 851 - 851 (e)	839 - 851 - 851 (e)	839 - 851 - 851 (e)	843 - 866 (e)	839 - 851 - 851	843 - 866	843 - 866
	3.7	Track width, rear	b11 (mm)	199 - 229 (e)	199 - 229 (e)	199 - 229 (e)	199 - 229 (e)	199 - 229 (e)	199 - 229	199 - 229
	Dimensions	4.1	Mast tilt, forward/backward	$\alpha / \beta$ (degrees)	2°30' / 6°	2°30' / 6°	2°30' / 6°	2°30' / 6°	2°30' / 6°	2°30' / 6°
4.2		Height of mast, lowered	h1 (mm)	2160	2160	2160	2160	2160	2160	
4.3		Free lift	h2 (mm)	80	80	80	80	80	80	
4.4		Lift height	h3 (mm)	3170	3170	3170	3170	3170	3170	
4.5		Height of mast, extended	h4 (mm)	3720	3720	3720	3720	3720	3720	
4.7		Height of overhead guard	h6 (mm)	1950	1950	1950	1950	1950	1950	
4.8		Height of driver's seat	h7 (mm)	888	888	888	888	888	888	
4.12		Towing coupling height	h10 (mm)	630	630	630	630	630	630	
4.19		Overall length	l1 (mm)	2880 (b)	2920 (b)	2990 (b)	3030 (b)	3122 (b)	3122 (b)	3162 (b)
4.20		Length to fork face	l2 (mm)	1880 (b)	1920 (b)	1990 (b)	2030 (b)	2122 (b)	2122 (b)	2162 (b)
4.21		Overall width	b1/b2 (mm)	990-1003-1003/NO (e)	990-1003-1003/NO (e)	990-1003-1003/NO (e)	1006 - 1066/NO (e)	990 - 1003/NO (e)	1006 - 1066/NO (e)	1006 - 1066/NO (e)
4.22		Fork dimensions	s/e/l (mm)	35 x 100 x 1000	35 x 100 x 1000	35 x 100 x 1000	35 x 120 x 1000	35 x 100 x 1000	35 x 120 x 1000	35 x 120 x 1000
4.23		Fork carriage to DIN 15173, class/form A, B		II A	II A	II A	II A	II A	II A	II A
4.24		Width of fork carriage	b3 (mm)	900	900	900	900	900	900	900
4.31		Floor clearance, mast (with load)	m1 (mm)	100	100	100	100	100	100	100
4.32		Floor clearance, centre of wheel-base (with load)	m2 (mm)	90	90	90	90	90	90	90
4.33	Aisle width with pallets 1000 x 1200 across forks	Ast (mm)	3208	3248	3318	3358	3450	3450	3490	
4.34	Aisle width with pallets 800 x 1200 along forks	Ast (mm)	3332	3372	3442	3482	3574	3574	3614	
4.35	Turning radius	Wa (mm)	1517	1557	1627	1667	1759	1759	1799	
Performance	5.1	Travel speed, with/without load	km/h	14.5 / 14.5	14.5 / 14.5	14.5 / 14.5	14.5 / 14.5	14.5 / 14.5	14.5 / 14.5	
	5.2	Lifting speed, with/without load	m/s	0.4 / 0.6	0.4 / 0.6	0.4 / 0.6	0.38 / 0.6	0.4 / 0.6	0.36 / 0.6	
	5.3	Lowering speed, with/without load	m/s	0.55 / 0.50	0.55 / 0.50	0.55 / 0.50	0.55 / 0.50	0.55 / 0.50	0.55 / 0.50	
	5.5	Tractive force, with/without load	N	5200 / 5400	5200 / 5400	5200 / 5400	5200 / 5400	5200 / 5400	5200 / 5400	
	5.6	Maximum tractive force, with/without load, S2 5 minute rating	N	14450 / 15000 (d)	14450 / 15000 (d)	14450 / 15000 (d)	14450 / 15000 (d)	14450 / 15000 (d)	14450 / 15000 (d)	
	5.7	Climbing ability, with/without load, S2 30 minute rating	%	14 / 16.5	13.5 / 16	13 / 15.5	12.5 / 15	13 / 15.5	12.5 / 15	
	5.8	Maximum climbing ability, with/without load, S2 5 minute rating	%	27 / 32 (d)	26.5 / 31.5 (d)	26 / 31 (d)	25.5 / 30.5 (d)	26 / 31 (d)	25.5 / 30.5 (d)	
5.10	Service brake: mechanical/hydraulic/electric/pneumatic		hydraulic	hydraulic	hydraulic	hydraulic	hydraulic	hydraulic		
Electric motor	6.1	Drive motor, S2 60 minute rating	kW	6 x 2	6 x 2	6 x 2	6 x 2	6 x 2	6 x 2	
	6.2	Lift motor, S3 15% rating	kW	12	12	12	12	12	12	
	6.4	Battery voltage/rated capacity (5 h)	V/Ah	48 / 420 - 500	48 / 420 - 500	48 / 525 - 625	48 / 525 - 625	48 / 630 - 750	48 / 630 - 750	
	6.5	Battery weight	kg	775	775	920	920	1090	1090	
Others	8.1	Type of drive control		Inverter MOSFET	Inverter MOSFET	Inverter MOSFET	Inverter MOSFET	Inverter MOSFET	Inverter MOSFET	
	8.2	Working pressure for attachments	bar	140	140	140	140	140	140	

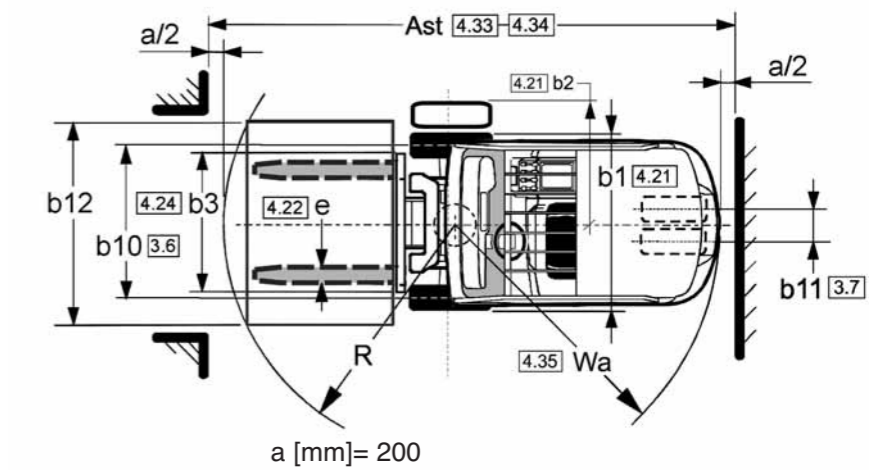
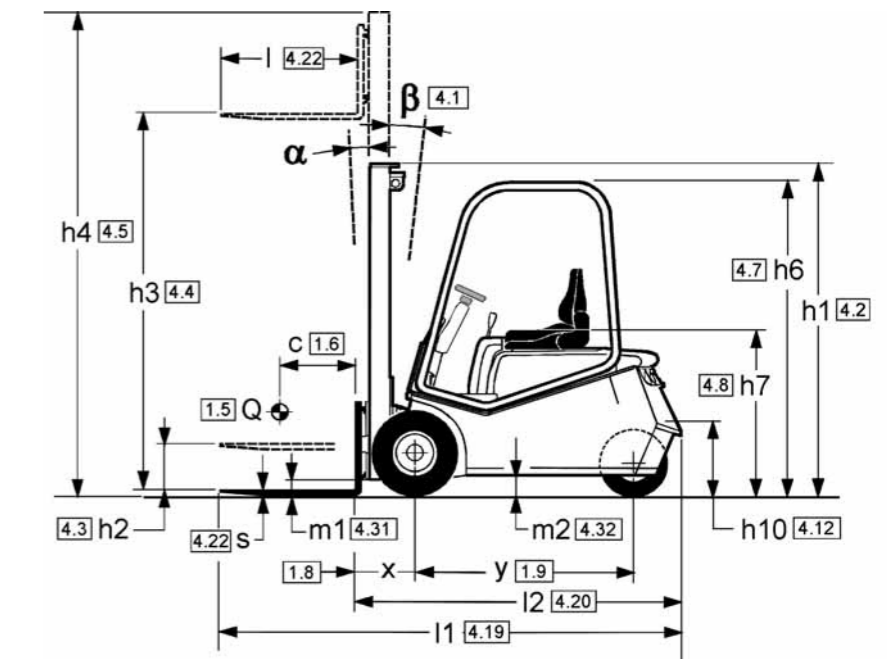

Masts specifications (1200 - 2000 Kg)										
Mast	mm	Duplex					Duplex FFL			
h3	Lift height	2970	3170	3670	4170	4670	2840	3170	3670	4170
h1	Height of mast, lowered	2060	2160	2410	2660	2910	1990	2160	2410	2660
h2	Free lift	80	80	80	80	80	1410	1580	1830	2080
h4	Height of mast, extended	3520	3720	4220	4720	5220	3420	3750	4250	4750
$\alpha / \beta$	Mast tilt forward/backward	2°30' / 6°					2°30' / 6°			

Masts specifications (1200 - 2000 Kg)													
Mast	mm	Triplex					Triplex FFL						
h3	Lift height	4320	4965	5565	6165	6570	4270	4470	4970	5570	6170	6570	6970
h1	Height of mast, lowered	2010	2260	2460	2710	2860	1990	2060	2260	2460	2710	2860	3010
h2	Free lift	0	0	0	0	0	1410	1480	1680	1880	2130	2280	2430
h4	Height of mast, extended	4900	5570	6170	6820	7240	4850	5050	5550	6150	6750	7150	7550
$\alpha / \beta$	Mast tilt forward/backward	2°30' / 6°					2°30' / 6°						

(a) Battery included (b) With side shift = + 34 mm (c) PN only available with front tyres (d) Data refer to the electric motors and transmission capacity (e) C / SE  
 NOTES: Unless otherwise specified, all data refer to vehicles with SE tyres. All performance figures refer to fully run-in vehicles, in perfect working status with homologated tyres mix, battery fully charged and excellent conditions with closed circuit voltage equal to nominal value. Truck performance and dimensions are nominal and subject to tolerances.